

Basic AO Frequency Shifter Equations

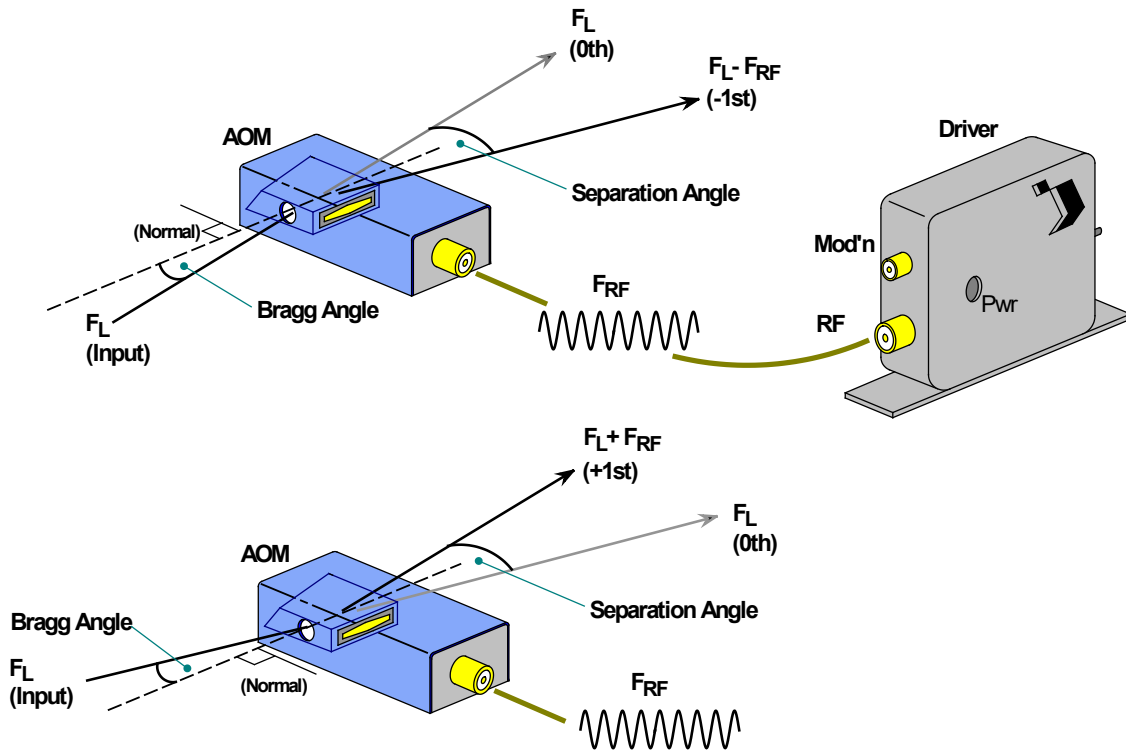

Input Bragg angle

$$\theta_{Bragg} = \frac{\lambda \cdot fc}{2 \cdot V}$$

Separation angle

$$\theta_{sep} = \frac{\lambda \cdot fc}{V}$$

Optical rise time

$$\tau_r = 0.65 \cdot \frac{d}{V}$$

Optimum RF drive power

$$P_{sat} = \frac{k \cdot \lambda^2 \cdot H}{2 \cdot L \cdot M_2}$$

Diffraction Efficiency

$$DE = \frac{I_{1st}}{I_{0th}}$$

Insertion Loss

$$IL = 1 - \frac{I_{0th}}{I_{Laser}}$$

Key:

λ = wavelength
 d = $1/e^2$ beam diameter

f = RF frequency
 fc = centre frequency
 Δf = RF bandwidth

V = acoustic velocity
 TeO2 (L): 4.2mm/us
 TeO2 (S): 0.62- 0.65 mm/us
 PbMoO4: 3.63mm/us
 Quartz: 5.7mm/us
 Ge: 5.5mm/us

L = interaction (electrode) length
 H = active aperture (electrode) height
 M_2 = AO Figure of Merit
 k = transducer conversion loss

I_{1st} = diffracted laser power
 I_{0th} = zero order (no RF) laser power
 I_{Laser} = input laser power